

Operating Manual



CE

Steamer CONVEX CS 608

convex[®]
steamer

1 Contents

1	Contents	3
2	Important References	4
2.1	Fundamental Safety Notes	4
2.2	Warranty and Liabilities	5
2.3	Symbols and Notes	5
2.4	Copyright.....	5
2.5	Special safety references	6
3	Product Information.....	8
3.1	Introduction.....	8
3.2	Special Features.....	8
3.3	Operation Methods.....	8
3.4	Technical Data	9
4	Installation and starting the operation.....	12
4.1	Unwrapping	12
4.2	Installation	12
4.3	Electrical connection.....	12
4.4	Tap.....	13
4.5	Preparation of Operation / Starting up	13
5	Operation.....	14
5.1	General functions	14
5.2	Operation panel.....	15
5.3	Explanation of the computer control (overview)	16
5.4	Operation, handling and cleaning of WRT probes (optinal accessory)	20
6	Maintenance	23
6.1	Safety advices	23
6.2	Trouble shooting.....	24
6.3	Wiring Diagram.....	26
6.4	Spare Parts	27
6.5	Exploded View.....	29
6.6	Declaration of Conformity	30

2 Important References

2.1 Fundamental Safety Notes

2.1.1 Consider notes in the operating manual

Precondition for the safe and trouble free use of this unit is the knowledge of the fundamental safety notes and safety regulations.

The operating instruction contains the most important references to operate the unit safely.

These operating instructions, particularly the safety references, are to be considered by all persons, who work on the unit.

Furthermore the rules and regulations to avoid accidents are to be considered.

2.1.2 Obligation of the operator

The operator is obliged to only let person's work with the unit who:

- Are familiar with the fundamental regulations of work safety and accident avoiding and who have been instructed how to operate the unit.
- Read and understood the chapter about safety and warning notes and have confirmed this by signature.

The safe conscious operation of the staff has to be examined regularly.

2.1.3 Obligation of the staff

All individuals who are authorized to work with the unit are obliged to:

Pay attention to the fundamental regulations of work safety and accident avoiding,

Read the chapter on work safety and warning notes in this manual and to confirm through their signature that they have understood these, before actually operating the unit.

2.1.4 Possible risks

CONVEX Steamers are built state of the art and in acknowledgement of all safety related rules. Nevertheless it is possible that danger for body and life of the user and/or third and/or impairments at the unit or at other real values merge. The unit is to be used only:

- For the due use.
- In safety related flawless condition.

Disturbances which can hurt the safety are to be eliminated immediately.

2.1.5 Due use

The CONVEX Steamers are built exclusively for the preparation of food only. Any other use of the unit is only allowed after consulting UBERT GASTROTECHNIK GMBH. Damages which result out of wrong use UBERT GASTROTECHNIK GMBH cannot be held responsible. Part of the due use is also:

- the consideration of all references of the operating manual and
- the observance of necessary maintenance and service.
- We recommend a semi-annual maintenance interval.

2.2 Warranty and Liabilities

Fundamentally our "General terms of sale and delivery" are valid. These are known to the operator at the latest since signing of the contract. Claims to warranty and liability at persons- and property damages are impossible, if they are to be led back to one or several of the following causes:

- Non due use of the unit.
- Improper assembling, starting up, operating and servicing of the unit.
- Operating the unit with defective safety devices or safety devices which have not been installed properly and are in no working condition.
- Disobeying of the references in the operating manual concerning transportation storage, installation, start-up, operation, maintenance and assembling of the unit.
- Unauthorized mechanical or electrical changes of the unit.
- Insufficient maintenance of wear and tear parts.
- Unauthorized repair.
- Force of nature and act of god.

2.3 Symbols and Notes

In the operating manual the following symbols and signs are used:



This symbol means a possibly or directly threatening danger for the life and the health of persons and/or a possibly dangerous situation.
Ignoring of these references may result in consequences for your health and/or can lead to property damages!



This symbol points to important references for the proper use of the unit.
Not paying attention to these references can lead to disturbances of the unit or of the environment!



This symbol points to operation tips and especially useful information.
Help to use all functions at your unit optimally

2.4 Copyright

The copyright on this operating manual remains with the company UBERT GASTROTECHNIK GMBH. This operating manual is intended only for the operator and his staff. It contains instructions and references which neither completely nor partially are to:

- be duplicated
- be circulated or
- be otherwise made available to third parties.

Offences may violate applicable laws.

2.5 Special safety references



2.5.1 Safety devices

- Before operating the unit all protective devices as well as all removable parts must be installed correctly and be fully workable.
- Protective devices may only be removed:
 - After stand still and
 - Prevention of unintentional restart.
- If partial components are delivered, an authorized staff member or service technician has to execute assembly according to installation guidelines.

2.5.2 Informal safety steps

- The operating manual is to be kept constantly accessible in the operating area.
- In addition to the operating manual all generally acknowledged and all local regulations for accident avoiding and environmental protection have to be applied with.
- All safety- danger labels at the unit are to be kept in readable condition.

2.5.3 Education of the staff

- Only trained and instructed staff is allowed to operate the unit.
- The responsibilities of the staff are to be determined clearly for installing, start-up, operation, assembling, and servicing of the unit.
- During instructing the staff may only work at the unit under supervision of an experienced person.

2.5.4 Unit-control

- Only instructed staff is allowed to operate the controls.

2.5.5 Safety during regular operation

- The unit is only to operate if all protective devices are fully workable.
- At least once per shift the unit is to be examined with regard to visible damages and functional ability of the safety devices.

2.5.6 Dangers caused by electrical energy

- Any work on the electrical supply is to be executed only by a specialist.
- Likewise the electrical connection of this unit to the power supply must be executed by an examined electrician; the connection must follow the rules of the local determinations.
- The electric installation is to be examined regularly. Loose connections and braised cables are to be eliminated immediately.
- If works at any life-parts are necessary, a second person who switches off the main switch if necessary is to consult.

2.5.7 Special danger-spots

- All removable parts like spit, disc or ventilation fan cover for instance, are only to be removed if the rotisserie is switched off and all surfaces, inner walls and parts are not hot anymore!
- Caution while removing grilled food! All parts may be hot and may cause severe burnings to your skin.
- Do not reach into the rotisserie while the appliance is hot and operating. Keep the doors closed at any time!

2.5.8 Service and maintenance, trouble shooting

- Prescribed adjustment, service and inspection work is to be accomplished timely by the manager or if necessary by an authorized service technician.
- The operating staff is to be informed before the beginning of the maintenance and service work.
- The unit is to be disconnected from the mains before maintaining, inspecting and repairing is done; the main switch is to be supervised against unintended reclosing.
- Check all screw connections for tight fitting.
- After finishing maintenance check all safety devices for proper functionality.

2.5.9 Structural changes to the unit

- Do not perform any changes, extensions or conversions to the unit without the manufacturer's permission, especially welding work at supporting parts.
- For all conversions a written permission of the company UBERT GASTROTECHNIK GMBH is necessary.
- Change all parts of the unit, which are in improper condition.
- Use only original spare parts.

2.5.10 Cleaning of the unit and disposal of the waste

Used substances and materials are to be handled and disposed appropriately, especially lubricants. Detergents have to follow the rules of food-hygiene.

3 Product Information

3.1 Introduction

3.2 Special Features

- Compact design
- Air humidification / steam injection
- Hot air convection
- Steam (incl. enforced steam)
- Combi steam
- Regeneration
- Tray control
- Core temperature probe
- Computer controlled
- Clear-type display
- Double glass door
- Self-diagnostic error detection system
- Programmable
- Automatic Self Cleaning
- Cool down function

3.3 Operation Methods

3.3.1 Manual Operation

The 4 basic modes hot air convection, steam (incl. enforced steam), combi steam and regeneration can be operated manually. In the manual operation all settings (temperature, core temperature, time, fan speed and steam) can be set and run without prior programming. In these modes the settings can be set before start and changed during runtime.

3.3.2 Programmed operation

The programmed operation can use up to 250 programs each with up to 9 cooking steps. One of the 4 basic modes can be used in each cooking step. Settings cannot be changed by regular operators

3.3.3 Full automatic self-cleaning

The machine is equipped with several programs performing full automatic self-cleaning cycles.

3.4 Technical Data

3.4.1 Dimensions (all measures in [mm])

CS 608:

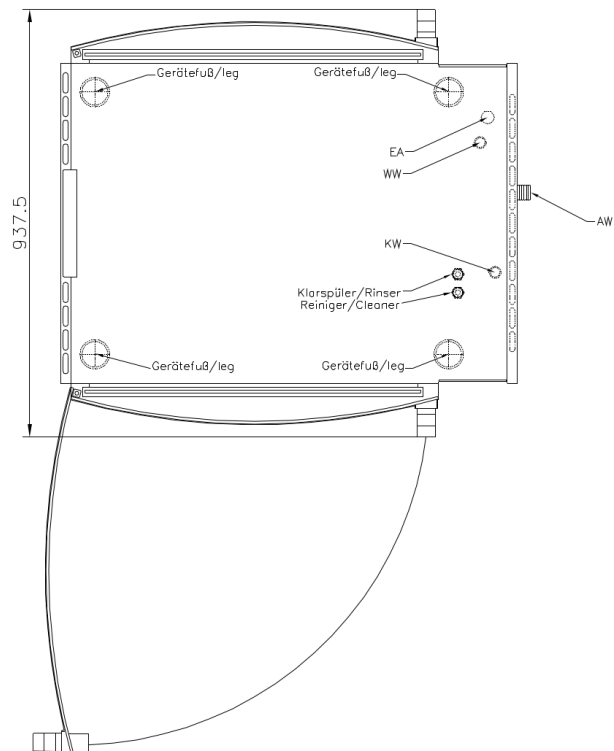
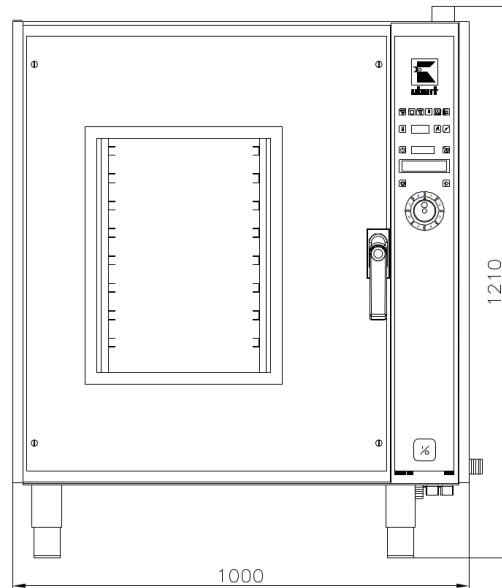

CKT2000:

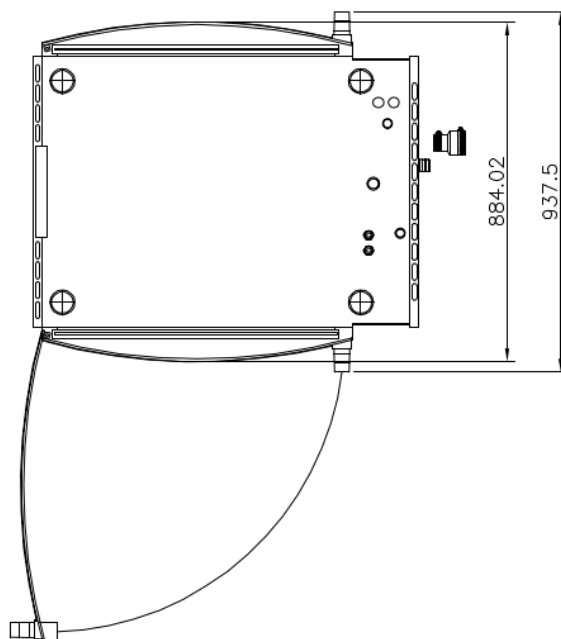
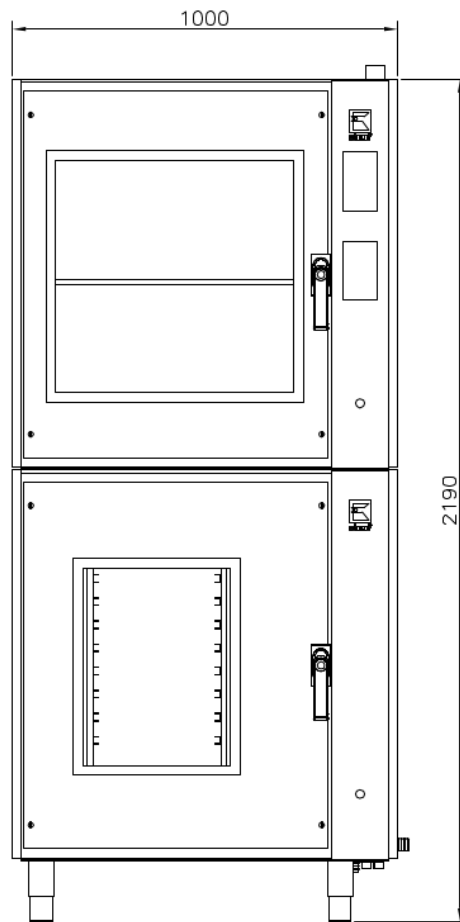
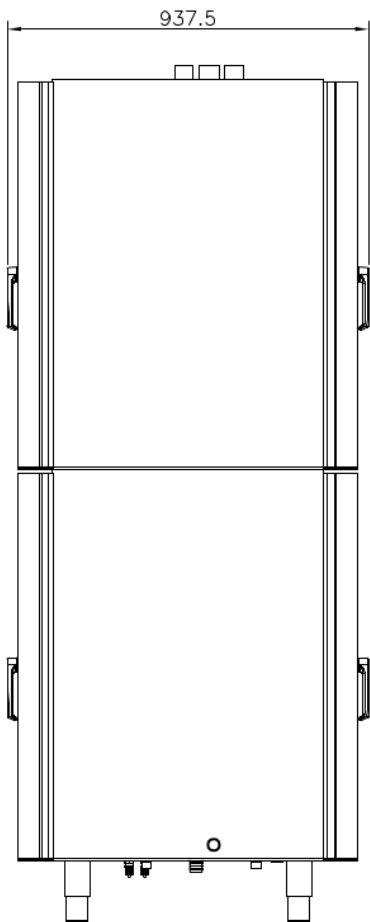

3.4.2 Weight

Type	Net weight (in kg)
CS 608	app. 197
CKT 2000	app. 425

3.4.3 Electrical ratings

Type	Electrical connection [EA]	Nominal Power
CS 608	380V, 3 Ph. N, 50-60Hz	12.0kW
CKT 2000	380V, 3 Ph. N, 50-60Hz	24.3kW

3.4.4 Noise emission

Type	Noise emission
All types	< 70 dB (A)

4 Installation and starting the operation

In general all CONVEX Steamers will be packed for safe transport after the final control in order to reach you properly. Nevertheless we ask you to have a look at the machine on arrival to check on any possible transport damages.

Note! Visible damages have to be reported immediately!



4.1 Unwrapping

- Open the carton and take out the wrapping material carefully.
- Take care that the delivery is complete (see attached freight documents).

4.2 Installation

Place the CONVEX Steamer at the desired location.

Take care of the following:

- The CONVEX Steamer (with or without stand) has to be placed on a horizontal level. Use a spirit level if necessary.
- Location underneath a ventilation hood system is useful and recommended.
- There has to be enough free space to load, unload, clean and maintain the unit.
- The machine should be placed in a way that the area around it can be cleaned easily.



4.3 Electrical connection

Note! In general, only service technicians of the company: UBERT GASTRO-TECHNIK GMBH or service technicians of your responsible service partner are allowed to perform electrical connection and other service! All national and local rules and regulations concerning electricity, fire protection and similar have to be considered. During any servicing, take care that the unit is disconnected from the mains! Not paying attention may result in injury!



Please learn the electrical and technical data of your unit from the name plate.

- Check whether your local electrical power supply is in accordance with the data on the name plate.
- The power supply needs to be manufactured from heat resistant, flexible cable. It is to be routed to prevent any contact to hot parts.
- The unit is to be connected to the power supply either by means of an appropriate plug or if connected permanently, a switch (interrupting all poles) is to be provided on site. In case of an emergency the power supply must be interruptible immediately.

For further information please see the wiring diagram.

Note!

After finishing any installation work, maintenance or repairs check whether the ground wires are connected properly to the casing.



4.4 Tap

Note! In general all Installation and service work has to be done by an authorized service technician! The following regulations have to be observed: DIN EN 1717 (alt DIN 1988, Part4, technical regulations for drinking water installation/TRW.



- CONVEX Steamers require a cold water connection. We recommend using a water-softening unit in case of water hardness above 6° dH (= Level 1).
- In case water softening is required, soft water and cold water can be supplied separately to keep down the cost for the water softening.
- Use flexible pressure hose 1/2" with 3/4" screw joint. A faucet as well as a flow-back-prevention has to be provided on site.
- Water pressure should be between min. 250 kPa and max. 450 kPa. Use a pressure reducer in case of a water supply pressure above 450 kPa.

4.5 Preparation of Operation / Starting up

Before you can operate the CONVEX Steamer you should remove all protective foil on the surfaces. Clean the outside of the unit and all removable and accessory parts (e. g. spits, discs etc.) carefully with a grease solvent detergent. Afterwards you have to dry all surfaces.

Note! Do not use flammable cleaners. Do not use high-pressure cleaning, water pressure cleaning or steam jet cleaning machines. You will have further information about this in the section cleaning and maintenance".



After cleaning the CONVEX Steamer properly the smell will be minimal when using it the first time. However smell from the insulation material might occur during first heat up. This is normal.

The service technician assisting the commissioning, has to connect one end of the red and blue flexible tubes to the cleaner- and rinsing agent pump and the other end to the cleaner and rinsing agent canister. Afterwards he will access the service modes test area to switch on cleaner pump and rinsing agent pump, let each of them run for at least 20 seconds to ensure the tubes are filled with cleaner / rinsing agent. Afterwards cleaning program 2 should be started to clean the complete interior and prepare the CONVEX Steamer for the first use.

5 Operation

Following position and function of all components are specified and explained, which are important for the operation of CONVEX Steamers.

5.1 General functions

5.1.1 Switch the steamer on / off

To operate the steamer, press the ON/OFF switch at the bottom end of the operation panel. The controller will start, showing the manufacturer logo and will boot into the home screen.

To completely switch off the steamer, press the O/I switch at the bottom end of the operation panel again.

5.1.2 Core Temperature

The function Core Temperature is available, whenever the door is open. By opening the door, the wire-connected core temperature probe will be activated and the current temperature at the tip of the probe is shown in the display. After the door is closed again the temperature display shows the actual oven temperature again.

5.1.3 Cleaning prompt

A message frequently appears on the display prompting the operator to clean the Rotisserie with any of the cleaning programs 2-6. The frequency of the message can be adjusted in the user parameter section between 0 (= no message) – 24 operating hours

5.1.4 Special Recommendation

- In case the CS608 works as the bottom unit of a CKT2000 please do not operate (cook inside) the unit whilst the RT608 on top is running a fully automatic cleaning cycle.
- It is recommended to run cleaning cycles in both units at the same time.



5.2 Operation panel

5.2.1 Operating panel

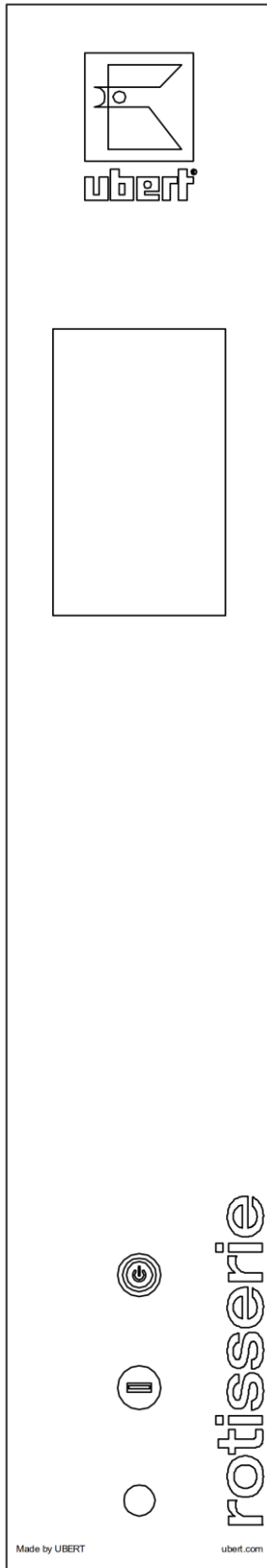







- **Computer control**
The controller is used to control the complete cooking process automatically, including cooking time period, cooking temperature and cooking end time.

Note: In case the steamer is part of a CKT2000, the controller might be mounted in the rotisserie above the steamer

- **Main switch to switch the steamer ON and OFF:**
- **USB-Port to connect a USB Data-Stick allowing:**
 - to create backup and restore of cooking programs
 - to update the firmware of the controller

5.3 Explanation of the computer control (overview)

The computer control offers 6 keys on the home menu that represent the main sections:

	<p>In the cooking section, you can:</p> <ul style="list-style-type: none"> - select from and run various predefined cooking programs - select and run a boost program (if enabled) - use the manual mode (if enabled) to cook the products without predefined settings
	<p>In the cleaning section, you can:</p> <ul style="list-style-type: none"> - select from and run various predefined cleaning programs such as Clean 1: a short rinse with clear water- Clean 2-6: a combination of up to 5 washing cycles plus a rinsing cycle- Clean 7: A program to evacuate the air from both media suction hoses (after connecting new canisters).
	<p>In the programming section you can preset cooking programs.</p> <p>You can use settings from the library or set all parameters from scratch. Cooking programs can be:</p> <ul style="list-style-type: none"> - batch-programs (to cook a full batch of products at a time) - vario-programs (to cook similar products at the same oven climate but with individual cooking times or target core temperatures)
	<p>In the user parameter section you can adjust various personal preferences such as language, access code (factory default is 1965), date&time, enable/disable a wire-connected core temp. probe, enable the manual mode or a boost program or disable both, pair/unpair WRT probes (wireless temperature probes), select the temperature scale (°C/°F), set the max. amount of batch grilling phases, select how long the lamp to be activated, enable/disable automatic program start and end, set frequency and volume of the buzzer, backup cooking programs to or restore them from a USB stick.</p>
	<p>In the help section, you get detailed information on all keys and functions.</p> <p>The help key can be pressed at any time to get specific information on the actual screen.</p> <p>Use the up and down key to scroll through the help pages. Press the back key to return back to the screen you came from.</p>
	<p>In the service section, you can</p> <ul style="list-style-type: none"> - read out the software version of the controller - confirm error messages after solving their cause. <p>Besides that, there is also a section included, that is reserved for service technicians.</p>

5.3.1 Cooking section

To operate the steamer via the computer control, press the ON/OFF switch. The controller will start, showing the manufacturer logo and will boot into the home screen.

5.3.1.1 Cooking section / manual operation mode:

Once the controller is ready, press the cooking section key and then the manual key to start the manual operation mode.

Press the TEMPERATURE key, and use the UP- und DOWN-key to change the set temperature
Use the CONFIRM key to confirm the temperature setting.

Press the TIME key, and use the UP- und DOWN-key to change the set time
Use the CONFIRM key to confirm the time setting.

Press the CONFIRM key again to start the cooking process.

Follow the instructions on screen to preheat, load, unload and so on. An acoustic alarm and the ready message on screen indicate the end of the cooking process. Use the CONFIRM key again, to quit the alarm. (If automatic program start and/or end is activated in the user parameter section, opening the door will quit the alarm automatically).

5.3.1.2 Cooking section / programmed operation mode

Once the controller is ready, press the cooking section key. Use the UP- and DOWN-key to scroll through the list of programs. Start the desired program by pressing the corresponding key. Follow the instructions on screen to preheat, load, unload etc. An acoustic alarm and the ready message on screen indicate the end of the cooking process. Use the START key again, to quit the alarm. (If automatic program start and/or end is activated in the user parameter section, opening the door will quit the alarm automatically).

5.3.1.3 Cooking section / boost

The "Boost" program key is always at the bottom of the list. This program is intended to be used in case of an insufficient core temperature at the end of a cooking cycle.

Follow the instructions on screen. An acoustic alarm and the ready message on screen indicate the end of the boost process. Use the START key again, to quit the alarm. (If automatic program start and/or end is activated in the user parameter section, opening the door will quit the alarm automatically). Re-check core temperature.

5.3.2 Cleaning section

5.3.2.1 Cleaning section:

Once the controller is ready, press the cleaning section key. Use the UP- and DOWN-key to scroll through the list of programs. Start the desired program by pressing the corresponding key. Follow the instructions on screen to support the automatic self cleaning procedure.

5.3.3 Programming section

Once the controller is ready, press the programming section key

Enter the access code (factory default is 1965) and confirm

You can choose between:

New to create a new cooking program

Change to change an existing cooking program

Copy (to copy an existing cooking program

Move to move an existing cooking program to a different location in the list

Delete (to delete an existing cooking program from the list)

5.3.3.1 New

Select the position of the new cooking program in the list

Select a program from the library or create your own (Batch- or Vario Program)

+ **Library** programs can be selected to the desired program position. They can be changed later on.

+ **Charge** (or Batch) programs are preset by the following steps:

- Select an Icon

- Enter a Name

- Set a preheat temperature (0=no preheat)

and for up to 8 cooking steps set an individual:

- Temperature

- Time or Core Temperature (requires WRT probe)

If a time \neq 0 is selected core temperature will not be available and vice versa.

If non of the them is set, the step will be skipped

and for a subsequent holding step:

- Temperature

- Time or Core Temperature (requires WRT probe)

If non of the them is set, there will be no holding step

+ **Vario** programs are preset by the following steps:

- Select an Icon

- Enter a Name

- Set a temperature and for up to 8 sub programs set an individual:

- Time or Core Temperature (requires WRT probe)

If a time \neq 0 is selected core temperature will not be available and vice versa.

5.3.3.2 Change

Works the same way as New except for the fact, that the given data can be changed or further steps can be added.

5.3.3.3 Copy

Select the source program that you want to copy from the list.

Select the position in the list, to which you want to copy the program to.

5.3.3.4 Move

Select the source program that you want to move in the list.

Select the position in the list, to which you want to move the program to.

5.3.3.5 Delete

Select the program that you want to delete from the list.

5.3.4 User parameter section

In the user parameter section you can adjust various personal preferences like:

- Select the language.
- Enter a new access code (factory default is 1965).
- Adjust date and time of the real time clock.
- Enable or disable a wire connected core temp.probe.
- Enable the manual mode or allow a boost program to be used or disable both.
- Pair and unpair WRT probes (wireless core temperature probes).
- Select the temperature scale (°C/°F).
- Set the maximum amount of charge grilling phases, cooking steps of batch cooking programs (1-9)
- Set an emptying prompt for the grease collector drawer in cooking hour steps (0=no prompt).
- Select which warming lamp to use (front, rare, both or none).
- Enable or disable automatic program start and automatic program end (to skip the need to confirm)
- Set the frequency (low to high) and the volume (low to high, 0=off) of the buzzer.
- Create a backup of your cooking programs to a USB stick or restore them from a USB stick.

5.3.5 Help section

In the help section, a general help on how to navigate the controller, is provided. Besides that, you can press the HELP-key (?) at any time to get specific information on the actual screen.

Use the UP-key (^) and DOWN-key (v) to scroll through the help pages. Press the BACK-key (<) to return back to the screen you came from.

5.3.6 Service section

In the service section, you can read out the software version of the controller and you can confirm error messages after solving their cause.

Besides that, there is also a section included, that is reserved for service technicians.

5.4 Operation, handling and cleaning of WRT probes (optinal accessory)

Activate the probe charger

To activate the probe charger (cradle), open the magnetic rear cover and remove the protective shield from the charger battery.

To verify the status of the charger battery, press the push button. If the LED lights up green, the charger battery is ok. If not, replace the charger battery (AAA size).

Description of WRT probe

The WRT probe is made is stainless steel. It measures the core temperature at the pointed tip.

Note the safety notch!

The thicker, black coloured end is the ceramic handle.

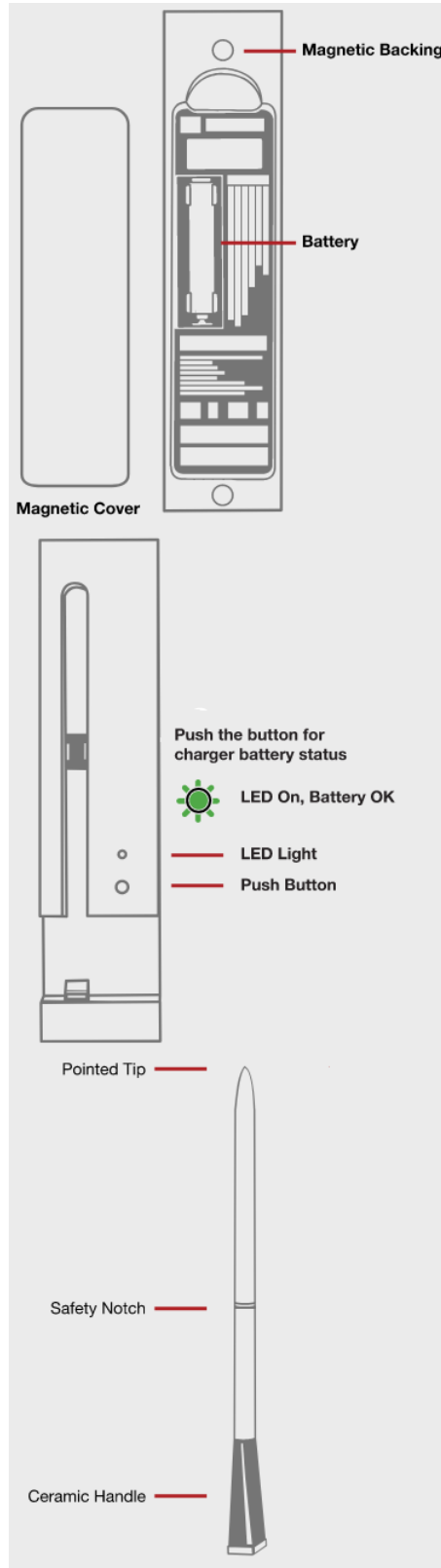

Loading the WRT probe

To load the built-in, re-chargeable battery of the WRT probe, place the probe in the cradle by inserting the tip of the probe first and then the black handle.

Once fully loaded, the re-chargeable battery lasts at least 24 hours.

Allow a new probe to load fully, by keeping it in the charger for 8 hours.

Later, reloading the probe takes only 2-3 hours.

We recommend to store the probe in the charger while it is not in use.

Proper probe placement

Insert your WRT probe in the centre of the thickest section of the meat.

Make sure the temperature critical section of the WRT probe, from the pointed tip to the safety notch, (shown below in grey) is completely inside the meat.



Allow the ceramic handle to stay outside the meat.



Chicken placement



Meat placement



Fish placement

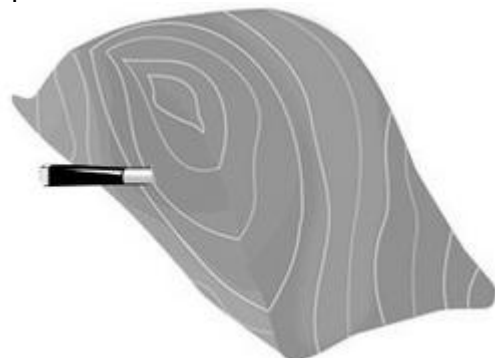

Identification of probes

To identify each probe when operating more than one probe with your rotisserie, probe clips are available. Place the clips onto the probe, adjacent to the ceramic handle.

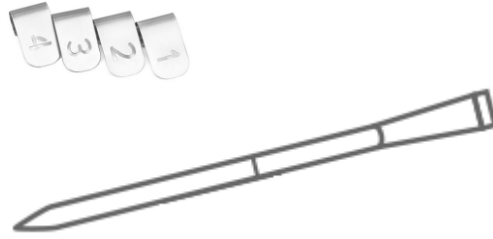

Cleaning and maintenance of the WRT probe

Make sure to clean the WRT probes after every use. This will ensure hygienic operation and debris-free charging contacts.

The WRT probe is water resistant so you can wash it with water. Use a sponge and mild soap to clean the probe.

If necessary, scrub the metal square above the ceramic handle to ensure proper re-loading of the internal battery.

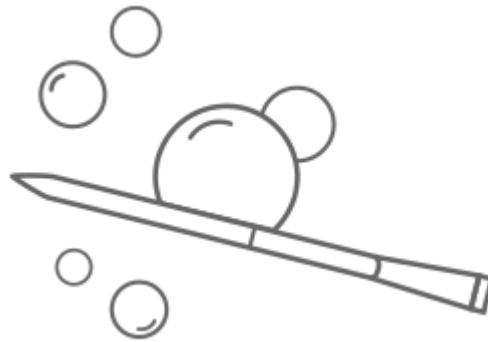

Do not submerge in water for a long period of time!

Do not clean the probe in a dishwasher!

Ensure to **clean and dry** the WRT probe **before** placing it in the charger!

We recommend to store the probe in the charger while it is not in use.

Overnight charging of the probe is recommended to ensure full loading and maximum capacity during worktime.

6 Maintenance

Following we will show you some advices concerning maintenance, care, trouble shooting and service for your CONVEX Steamer.

6.1 Safety advices

- When cleaning the outside of the steamer, switch off the unit before you start and disconnect it from the mains.
- Do not use inflammable detergents, sharp-edged or metallic things for cleaning the unit! Never use high-pressure-, water pressure- or steam jet- cleaning machines!
- Wear acid proof gloves while cleaning the parts to prevent skin irritations.



6.1.1 General Recommendations

- The unit has to be cleaned daily.
- Only use cleaning detergents that are appropriate for food (neutral or alkaline detergents), even if there are plain and persistent residues.
- After cleaning with special cleaners you have to wash all parts with clear water and dry them afterwards so that there are no residues of the cleaning detergent on these parts.
- It is absolutely necessary to watch out for some fundamental things to keep this long living high-grade-steel-machine working:
 - always keep the high-grade-steel surface clean.
 - watch out that there is always enough fresh air on the surface
 - never contact the surface with rusty material
- Never use bleaching or chlorine cleaners.
- Take brushes with plastic or natural bristles for cleaning.



6.1.2 Detergents

To make the cleaning fast and easy we have integrated some cleaners in our program:

- Special cleaner:
for the self-cleaning procedure.
- Rinsing Agent
for the self-cleaning procedure.
- Grill- and oven cleaner:
To dispose persistent, dried-up dirt on metal surfaces.
- Intensive cleaner:
Detergent for metal- and plastic-surfaces.
- Glass cleaner:
Removes fat from glass-surfaces.
- Stainless steel cleaner
You have to spray this from a distance of app. 25 cm on the surface and wipe it off with a dry cleaning rag. If you want to clean only small parts you have to spray it directly on the cleaning rag and wipe it off this way. With this method it is possible to clean the Steamer easily and without stripes.



6.1.3 Special cleaning hints

Please find below some special cleaning tips for this specific unit:

- Outside Glass:
Remove dust and dirt from the glass surface with soft cloth to avoid scratches.



6.2 Trouble shooting

If your Steamer does not work satisfactorily we would like to give a first help with the following check list. Only after checking these points you should contact:

- a) Your responsible service partner

Or

- b) Directly the company: UBERT GASTROTECHNIK GMBH
Werk II Gewerbegebiet Nord
Vennekenweg 17
46348 Raesfeld
Tel.:02865 / 602-226
Service-Tel.:0172 / 2 82 86 31
Fax:02865 / 602-102 (or -103)

Only these two companies are allowed to carry out service work and replacement of defect parts. If you do not observe this note or in case of manipulation of a third party any claims for guarantee will become invalid!



Check list of your CONVEX Steamer:

Trouble		Possible reason	remedy
1.	Steamer does not operate	Electrical supply is interrupted Fuse defect	Check the fuses! Unplugged? Call your local electrician!
2.	Fan motor does not work	mechanic hindrances Fan motor defect	Switch off the unit, remove the cover with ventilation grid, and check the ventilation on mechanic hindrances (e.g. hardened fat residues – remove these carefully)! Call your service company. Do not start the unit!
3.	Quartz lamp is off	Lamp is defect.	Replacement of the quartz lamp by a local electrician.
4.	Steamer does not reach the required temperature.	Electrical supply is not o.k. Heating elements are defect. Fan defect. Temperature regulation defect.	Check the fuse box! Call the service! See point 2 or call the service! Call the service!

6.3 Wiring Diagram

CS 608

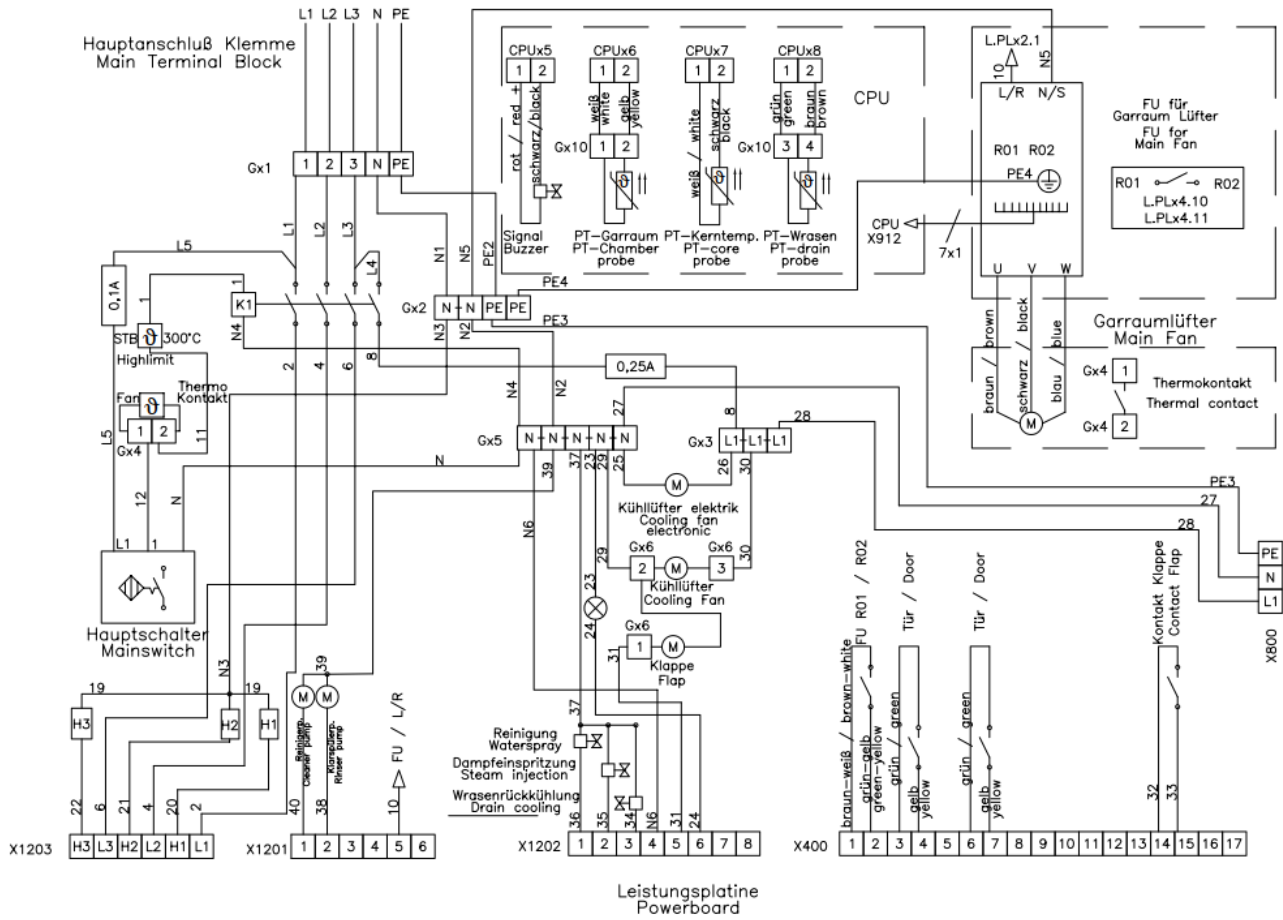

6.4 Spare Parts

Defect parts are to be replaced only by original spare parts of UBERT GASTROTECHNIK GMBH; the replacement is to be carried out only by their service staff or by your authorized service companies. If you do not observe this note or in case of manipulation of a third party any claims for guarantee will become invalid! Also all certifications (CE, UL, NSF and the like) become invalid!



6.4.1 Spare Part List

CS608

Amount	Part No.	Description	Dimension	VT
1	419013	Decor glass RT508	1009*148	X
2	342295	reed switch (door switch)		
1	380123	Flap motor		
1	380690	Driveshaft Flap RT608/CS608	D7x74 mm	
1	344145	Axial Fan		
8	316430	flat gasket - PTFE/black	8*18*1	X
6	370208	bronze flange adaptor for hinge		X
1	419015	Decor glass RT508	1009*148	X
1	342290	High limit switch 300°C normally closed		
1	342239	Screw joint for temperature probe 342237&342245	4mmxM8	
1	342260	Core Temperatuer Probe		
2	316439	Slip Ring Top for Spraying Arm RT608/CS608	14,5*19,5*4	X
2	316440	Slip Ring Bottom for Spraying Arm RT608/CS608	14,5*21*4	X
1	343336	Glas cover for oven light	76,5*61,5*4	X
2	342237o	Temperature probe PT100		
3	342239	Screw joint for temperature probe 342237&342245	4mmxM8	
1	343188	Heating element 11,0kW		
3	355780	Nozzle stainless steel		
1	344161	Fan Motor (hot air fan)	d=350*127	
1	344160	Fan Wheel (hot air fan)	d=350*127	
1	344117o	fan axial 80x80 240V 50-60Hz	80*80*38	
1	355434	Solenoid Valve Twofold		
1	355432	Flow Limiter (white)		
2	346057	Reciprocating plunger type pump 230V		
4	346056	Rubber mounting bracket for Fresh-water pump		
1	420711	Door Glass (outer door operator side)	815*1000*6	X
1	420714	Door Glass (outer door customer side)	815*1000*6	X
2	420702	Door Glass (inner door)		X
2	359166	Door gasket	618,8-10x493,8-10	X
1	340830	Controll Board UUS03		
1	340825	Power Board UUS02		
1	340950	Frequency Converter		
1	342412	Contactactor 26A 220-240V 50/60Hz		
1	340819	Buzzer 5-12V		
1	340814	Encoder for UUS01		

1	361315	knob, gas/electric, black		
1	360532	Scale disk 30-85°	d=44mm	
1	360440	Scale disk 30-85°	20x20	
3	333306	Sideblock (field-/main terminal block)		
6	333305	terminal block 10mm²		
3	333345o	Ground terminal block		
3	333308	Separator for terminal block		
16	333323	Terminal block 4qmm 4-pole		
5	333324	End cap for terminal block 4qmm 333323		
1	333307	Bridge for terminal block		
4	361135	Legs Stainless Steel, adjustable 120-180mm	d=65 mm	

6.5 Exploded View

6.6 Declaration of Conformity

UBERT GASTROTECHNIK GMBH
 Gewerbegebiet Ost + Nord
 D-46348 Raesfeld
 Telefon: +49 (0) 28 65 / 602-0
 Fax: +49 (0) 28 65 / 602-102
 Internet: www.ubert.com
 e-mail: info@ubert.com

Übersetzung der Original-EU-Konformitätserklärung



CE EU-KONFORMITÄTSERKLÄRUNG EU-DECLARATION OF CONFORMITY EU-CERTIFICAT DE CONFORMITE

Hereby we declare that the unit noted below, on the basis of its concept, design and version, meets all basic health and safety requirements of the applicable EC-directive. This declaration is no longer effective in case this machine has been modified without our approval.

Product designation: Combisteamer

Model: CS608

CKT2000

EC-directives followed: EC-directive for machines **2006/42/EC**

EC-directive for low voltage **2014/35/EU**

EC-directive for electromagnetic compatibility **2014/30/EU**

EC-directive for ecodesign requirements for energy-related products **2009/125/EC**

EC-directive for restriction of the use of certain hazardous substances **2011/65/EU**

Harmonized European Standards: **EN 55014** Electromagnetic compatibility – Requirements for household appliances

EN 61000-6-2 Electromagnetic compatibility – Generic immunity standard

EN 60335-1 Safety of household and similar electrical appliances

EN 60335-2 Safety of household and similar electrical appliances

Applied national standards and technical specifications: **BGR111** directions for safety and health protection regarding kitchen work

This declaration does not include any assurance of characteristics.

The safety references enclosed with the product documentation have to be followed.

By internal actions it is guaranteed, that all serial units meet the demands of the corresponding EC directive and the applied standards.

The signers are entitled to compose the technical documents.

Raesfeld, 01.01.21
 UBERT GASTROTECHNIK GMBH

 Christoph Stephan
 Vice President, R&D / Engineering

Raesfeld, 01.01.21
 UBERT GASTROTECHNIK GMBH

 Michael Peters
 Service - Manager

Manufactured by: UBERT GASTROTECHNIK GMBH
 Gewerbegebiet Ost + Nord
 D-46348 Raesfeld